

CANinspector

End of Line inspection system



Secure your production quality...

End of line inspection system for Aerosol cans to ensure stable production quality to your customer.

Let us know your preferred camera system and we will integrate it seamlessly into the machine or specify the different inspection you need and we propose a complete solution for you.

Main features

- Full body inspection to the bottom
- Print inspection
- Surface inspection
- Neck inspection
- Dimension check
- Leak inspection

Your benefits

- ▷ Quality statistics and analysis
- ▷ State of the Art operation and control system (Siemens Simotion)
- ▷ Integration into your production system
- ▷ Best value for money
- ▷ Lifetime upgrade service

Technical specifications

CANinspector Ci-8

Diameter range:	35 - 80 mm
Product length:	70 - 280 mm
Production speed:	up to 240 cpm
Inspection station:	5 (2 with rotation)
Size part chucks:	8

CANinspector PRO Ci-12

Inspection station:	8 (4 with rotation)
Bottom inspection:	2 positions
Size part chucks:	12

For more information

Contact our Managing Director Marcel Gut for a personal introduction of the equipment including all the features and service we can offer.

Visit our website to see more details and a short video

www.mg-servetec.com/caninspector

MG.SERVE.TEC CO., LTD.

M +66 81 751 0389

T +66 38 018 125

info@mg-servetec.com



CANinspector

End of Line inspection system



Technical data

CANinspector Ci-8

- 1) Loading station
- 2) **LEAKinspector** ¹⁾
- 3) Inspection ²⁾
- 4) Inspection ²⁾
- 5) Top inspection
- 6) Dimension check
- 7) Unloading station
- 8) free

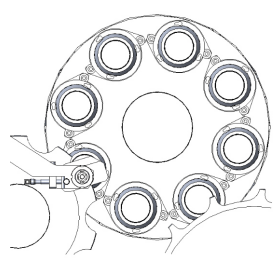

CANinspector PRO Ci-12

- 1) Loading station
- 2) free station
- 3) **LEAKinspector** ¹⁾
- 4) Inspection ²⁾
- 5) Inspection ²⁾
- 6) Inspection ²⁾
- 7) Inspection ²⁾
- 8) Top inspection
- 9) Dimension check
- 10) Unloading station
- 11) free
- 12) free

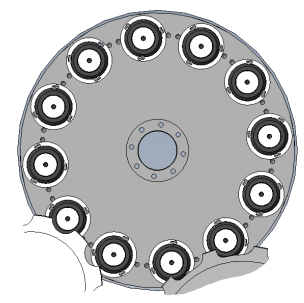

¹⁾ Light testing unit from MG.SERVE.TEC for pinhole detection down to 50 microns
²⁾ Inspection station with up to 2.5 rotations during dwell cycle and camera system based on customer requirements

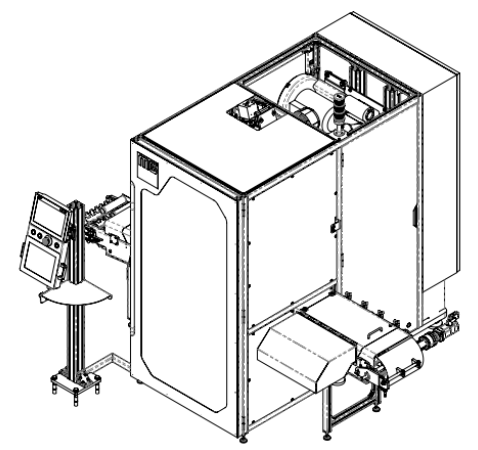
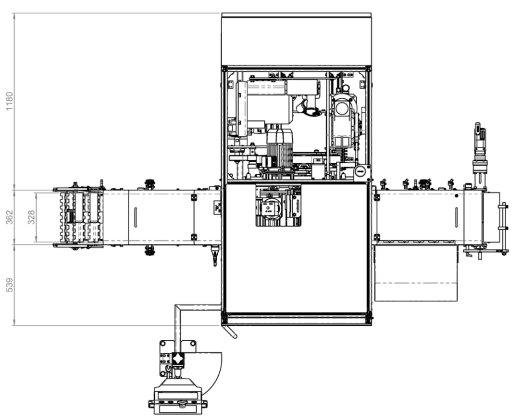
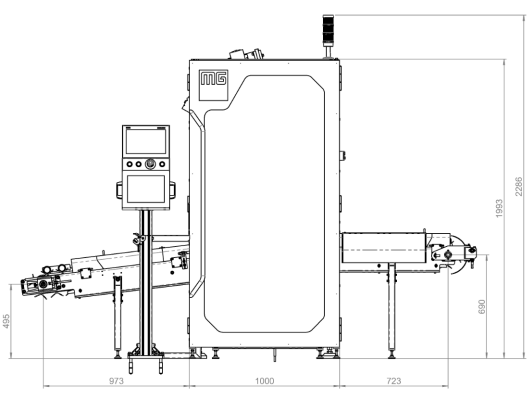

MG.SERVE.TEC CO., LTD.
 9/28 Moo 3
 T. Sumnakthon, A. Banchang,
 Rayong 21130, Thailand
 M +66 81 751 0389
 T +66 98 274 5030
info@mg-servetec.com
www.mg-servetec.com